

# TAO10.PD



caratteristiche/features



peso/weight



rotazione/rotation



prestazioni/performance

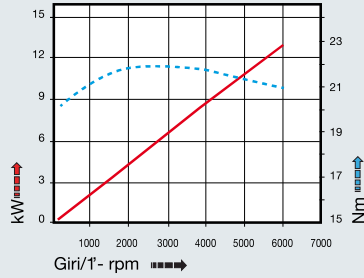

CONO SHANK	size	A	B	H	
				standard	optional
* DIN69871	40	184,5	35	65	-
	45			80	110
	50			80	110
* ANSIB5.50	40			65	-
	50			80	110
* BT	40			65	
	50	192,5	45	80	110
DIN69893	63	193,5	44	65	
	80			80	110
	100	46	80	110	
ISO26623	C5	188,5	39	65	
	C6			80	110
	C8			80	110
KM	63	184,5		65	
	80			80	110
	100			80	110
DIN2080	-			-	-
	-			-	-
	-			-	-
ANSIB5.18	NMTB			-	-
	-			-	-

tipi mandrino disponibili / available spindle types

- 2 Albero portafresce / Milling shaft
  - 4 DIN69893-HSK
- Ø16 HSK25

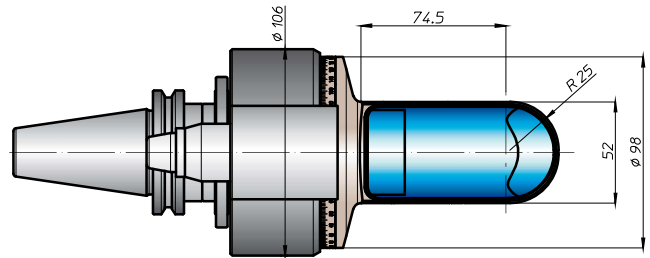
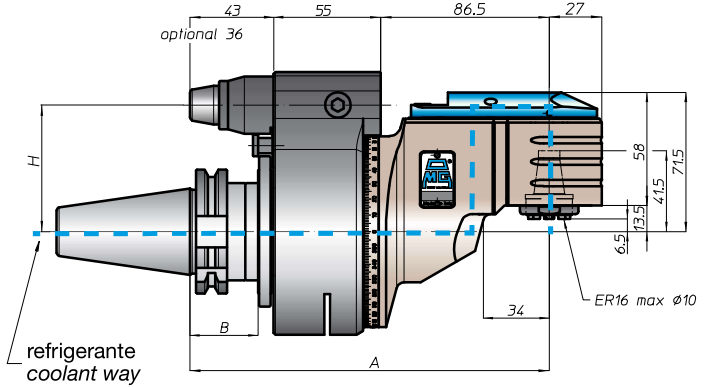
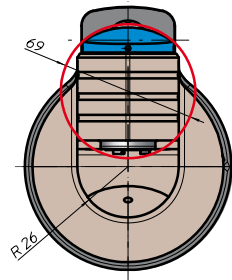

\* Option: Dual Contact

FH

BAH

TA-CP

TA

MOX

HT

VH

TSI/TSX

T

MT-TC-TC3

Accessori  
Accessories

Appendice tecnica  
Technical supplement

# TA013.PD



caratteristiche/features



peso/weight



rotazione/rotation



prestazioni/performance

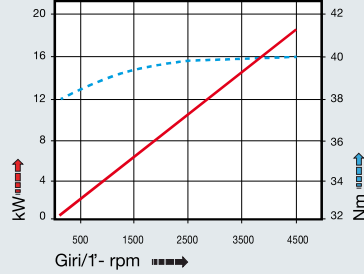

CONO SHANK	size	A	B	H	
				standard	optional
DIN69871 *	-	200	35	65	-
	40			80	110
	45			80	110
ANSIB5.50 *	CAT	200	35	65	-
	50			80	110
* BT	40	208	45	65	-
	50			80	110
DIN69893	HSK	209	46	65	-
	80			80	110
	100			80	110
ISO26623	CAPTO	204	39	65	-
	C5			80	110
	C6			80	110
KM	63	200	35	65	-
	80			80	110
	100			80	110
DIN2080	-	200	35	-	-
	-			-	-
	-			-	-
ANSIB5.18	NMTB	200	35	-	-
	-			-	-

tipi mandrino disponibili / available spindle types

- 2 Albero portafresce / Milling shaft
- 3 Weldon Whistle-Notch
- 4 DIN69893-HSK

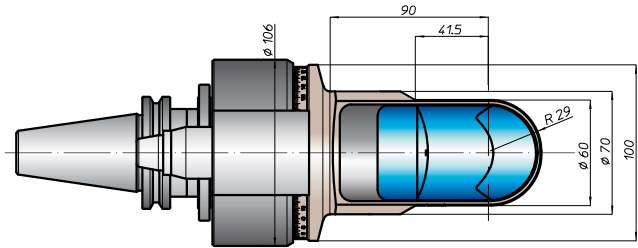
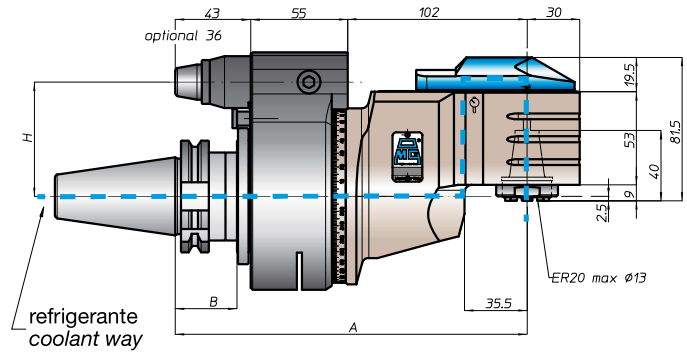
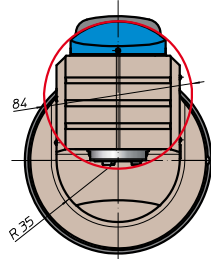

\* Option: Dual Contact

FH

BAH

TA-CP

TA

MOX

HT

VH

TSI/TSX

T

MT-TC-TC3

Accessori  
Accessories

Appendice tecnica  
Technical supplement

# TAO16.PD



caratteristiche/features



peso/weight



rotazione/rotation



prestazioni/performance

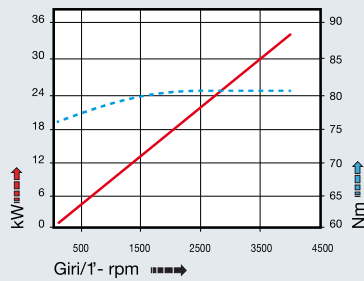

CONO SHANK	size	A	B	H	
				standard	optional
DIN69871 *	-	223,5	35	-	-
	45			80	110
	50			80	110
ANSIB5.50 *	-	232,5	46	65	-
	50			80	110
* BT	-	231,5	45	65	-
	50			80	110
DIN69893 HSK	-	232,5	46	-	-
	80			80	110
	100			80	110
ISO26623 CAPTO	-	227,5	-	-	-
	C8			80	110
KM	-	223,5	-	-	-
	80			80	110
DIN2080	-	-	-	-	-
	-			-	-
	-			-	-
ANSIB5.18 NMTB	-	-	-	-	-
	-			-	-

tipi mandrino disponibili / available spindle types

- 2** Albero portafrese Milling Shaft
  - 3** Weldon Whistle-Notch
  - 4** DIN69893-HSK
- Ø16-Ø22-Ø27      Ø16      HSK40**

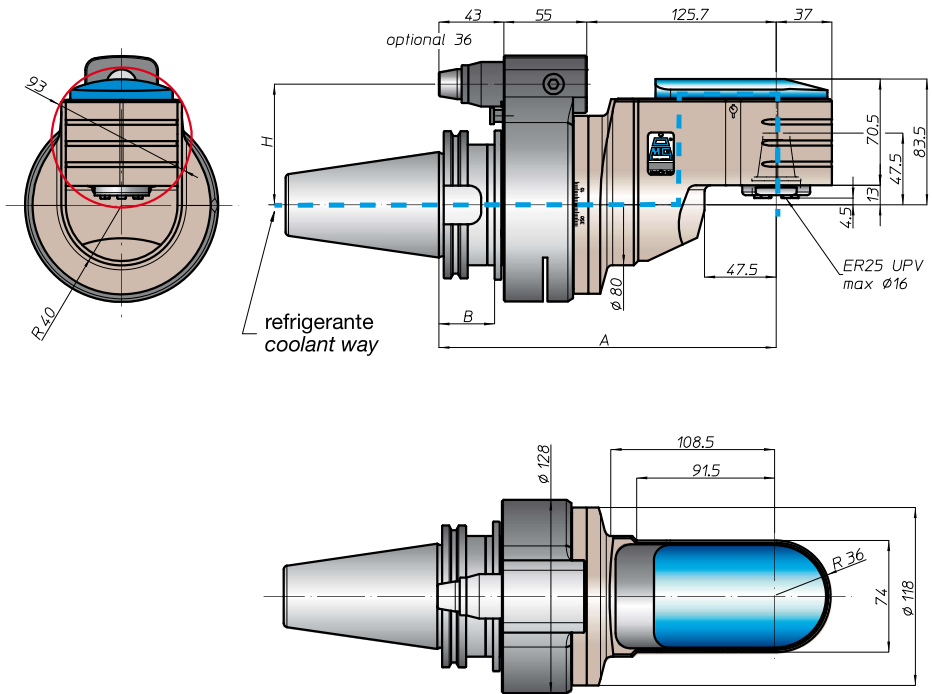

\* Option: Dual Contact

FH

BAH

TA-CP

TA

MOX

HT

VH

TSI/TSX

T

MT-TC-TC3

Accessori  
Accessories

Appendice tecnica  
Technical supplement

# TAO20.PD



caratteristiche/features



peso/weight



15 kg

rotazione/rotation



prestazioni/performances

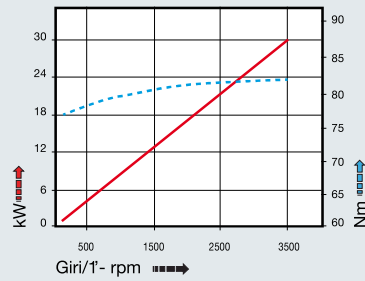

CONO SHANK	size	A	B	H	
				standard	optional
* DIN69871 *	-	230	35	-	-
	45			80	110
ANSIB5.50 *	-	230	35	-	-
	50			80	110
* BT	-	238	45	65	-
	50			80	110
HSK	-	239	46	-	-
	80			80	110
DIN69893	-	239	46	-	-
	100			80	110
CAPTO	-	234	-	-	-
	-			80	110
ISO26623	-	234	-	-	-
	C8			80	110
KM	-	230	-	-	-
	80			80	110
DIN2080	-	-	-	-	-
	-			-	-
ANSIB5.18 NMTB	-	-	-	-	-
	-			-	-

tipi mandrino disponibili / available spindle types

- 2** Albero portafresse  
Milling shaft
  - 3** Weldon  
Whistle-Notch
  - 4** DIN69893-HSK
- Ø22-Ø27-Ø32    Ø16-Ø20    HSK50**

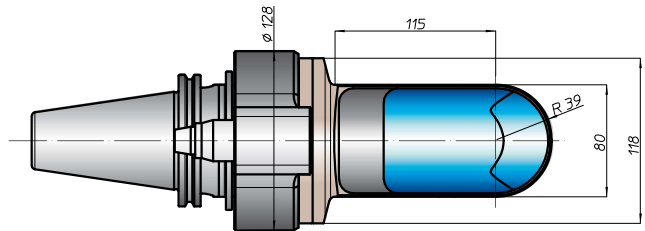
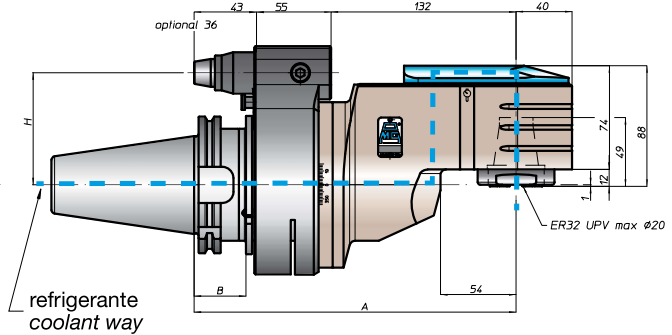
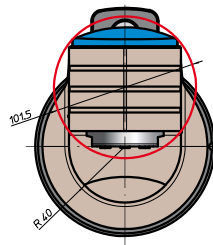

FH  
 BAH  
 TA-CP  
**TA**  
 MOX  
 HT  
 VH  
 TSI/TSX  
 T  
 MT-TC-TC3  
 Accessori  
 Accessories  
 Appendice tecnica  
 Technical supplement

\* Option: Dual Contact



# TAO26.PD



caratteristiche/features



peso/weight



24 kg

rotazione/rotation



prestazioni/performances

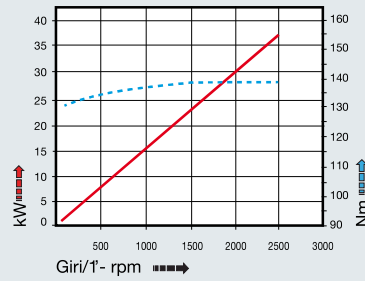

CONO SHANK	size	A	B	H	
				standard	optional
* DIN69871	-	264	36,5	-	-
	50			110	-
* ANSIB5.50	-	264	36,5	-	-
	50			110	-
* BT	-	272	44,5	110	-
	50			-	-
HSK	-	273	45,5	110	-
	100			-	-
CAPTO	-	264	36,5	-	-
	C8			110	-
KM	-	270	-	110	-
	100			-	-
DIN2080	-	-	-	-	-
	-			-	-
ANSIB5.18 NMTB	-	-	-	-	-
	-			-	-

tipi mandrino disponibili / available spindle types

- 2 Albero portafresse  
Milling shaft
- 3 Weldon  
Whistle-Notch
- 4 DIN69893-HSK
- 5 COROMANT  
CAPTO®
- 6 ABS  
Licenza KOMET®

Ø27-Ø32      Ø25-Ø32      HSK63      C4      ABS63

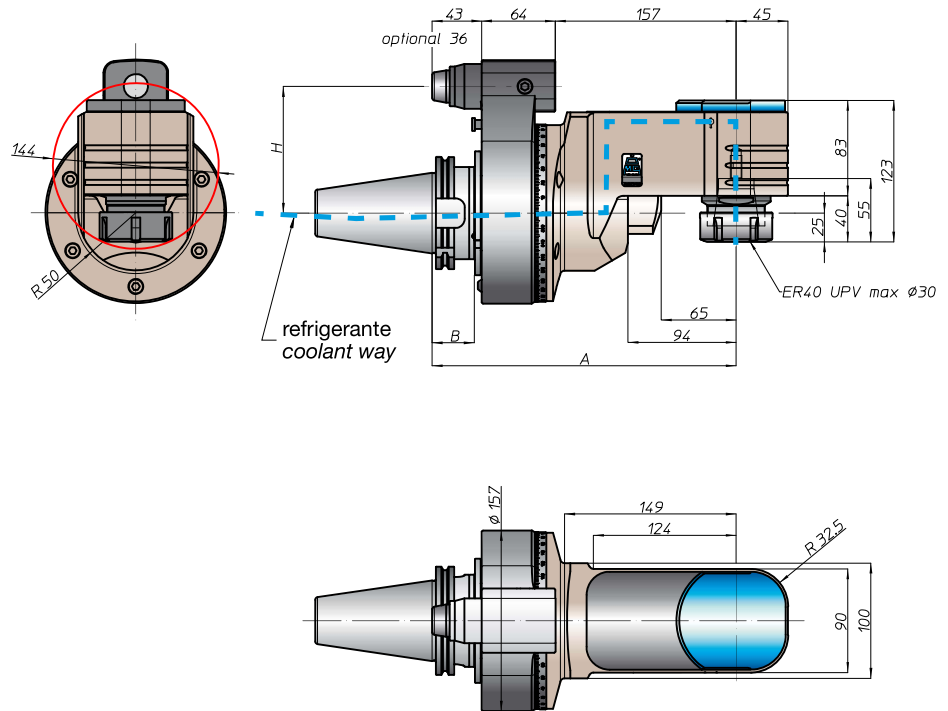

\* Option: Dual Contact